

MCR-304

Wireless Interface for Hard-Wire Control Panels



Visonic

Installation Instructions

1. INTRODUCTION

1.1 Purpose and Use

The MCR-304 is a single output wireless PowerCode / CodeSecure™ receiver designed to add fully supervised wireless capabilities to hard-wired alarm control panels, as demonstrated in Figure 1.

Up to 10 wireless devices can be used with the MCR-304 for alarm, panic or arm/disarm applications.

The MCR-304 will recognize only those devices with IDs that have been “taught” into its non-volatile memory. Other devices will be ignored. Detailed teaching/learning procedures are provided in Paragraphs 3.4 and 3.5.

The MCR-304 provides alarm, trouble, low battery and tamper outputs which are common to all 10 wireless devices.

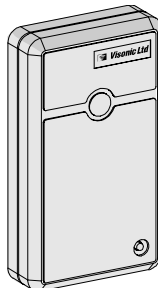

1.2 Alarm/Control Output

The MCR-304 features a single FORM-1C relay output that reacts to alarm/control signals received from up to 10 wireless detectors or hand-held transmitters. The relay can be programmed to operate in the **Pulse** or **Toggle** modes (see Para. 4.4 for full details).

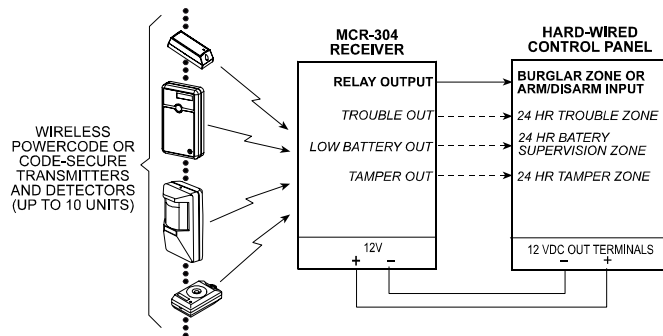

Figure 1. Typical Application of the MCR-304

1.3 Status Outputs

In addition to the single alarm relay output, the MCR-304 provides 3 open-collector status outputs that function as follows:

- **Tamper:** This output is activated once a TAMPER state is detected in a transmitter or in the MCR-304 receiver itself.
- **Low Battery:** This output is activated whenever a low battery message is received from one of the detectors/transmitters.

Replacing the battery in the transmitter that sent the low-battery message and transmitting once again resets the output.

- **Trouble:** This output is activated if a supervised transmitter fails to send its attendance message within a 4-8 hours time frame.

1.4 Construction Details

For construction details, refer to Figure 2.

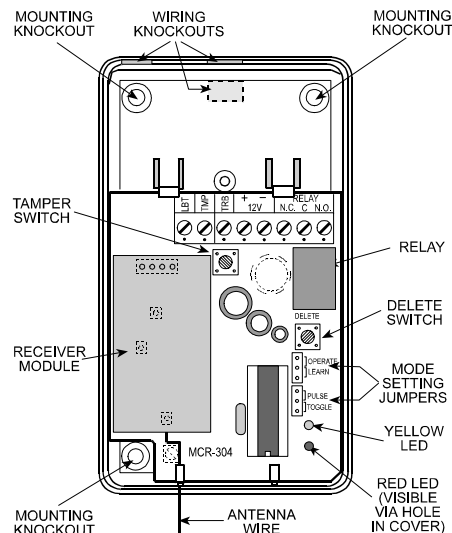

Figure 2. MCR-304 with Cover Removed

1.5 Receiver Operating Modes

Two operating modes are available:

- **OPERATE** - normal position (receiver stands by for signals)
- **LEARN** - enrollment of transmitter IDs in the MCR-304 memory.

1.6 LED Functions during Operation

SIGNAL indicator (red - visible through a hole in the cover): This LED illuminates when the output relay is energized and continues to light for as long as the relay remains energized. The LED extinguishes when the relay drops out.

Note: The red LED has a different function during the learning session (see Paragraphs 3.4 and 3.5).

Memory Location indicator (yellow - visible only when the cover is removed): This LED is extinguished in normal operation, but has a special function during the “learning” session.

2. SPECIFICATIONS

RF SECTION

Front-End Module: Super-regenerative UHF receiver.

Operating Frequency: Per local requirements in country of use.

DATA PROCESSING SECTION

ID codes: Over 16,000,000 possible 24-bit combinations.

Total Message Length: 36 bits (66 bits for code secure devices)

ID Learning Capacity: Up to 10 different ID codes

ELECTRICAL DATA

Relay Outputs: Form 1C (N.C. and N.O.)

Relay Contact Ratings: 1A resistive, 30 VDC or AC.

Status Outputs: 3, up to 100 mA each, open-collector type

Relay Output Modes: Pulsed (3 s) or toggle, jumper selected.

Tamper Switch Ratings: 0.1 A / 30 VDC.

Input Voltage Range: 10.5-16 VDC (MCR-304) or 24 VAC/DC (MCR-304U)

Current Drain (@ 12 VDC): 7 mA (standby), 32 mA (relay energized).

Compliance with Standards: FCC Part 15, CE (ETS 300220, ETS 300683)

PHYSICAL

Operating Temperatures: 0°C to 49°C (32°F to 120°F).

Dimensions (H x W x D): 110 x 63 x 25 mm (4-5/16 x 2-1/2 x 1”).

Weight: 76 g (2.7 oz).

3. PROGRAMMING

3.1 Helpful Hints

A learning session is required to let the MCR-304 learn the ID codes of individual wireless transmitters, which will all affect its single relay output.

The quickest way to conduct a learning session is on the work bench, with every transmitter you need within reach, and where you may observe the receiver's indicator LEDs.

3.2 Initial Steps

A. Remove the screw that secures the cover to the base and remove the cover as shown in Figure 3.

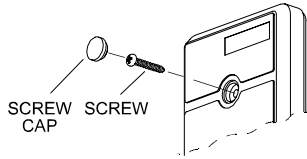

Figure 3. Cover Removal

B. Round up all transmitters to be used in the system and mark each one according to the desired deployment plan.

It is advisable to use the "transmitter deployment table at the end of this document.

C. Temporarily power up the MCR-304 by connecting a 12 V battery or a 12 VDC power supply across its 12 V input terminals (24 Volts AC or DC in case of MCR-304U). **Observe polarity!**

3.3 Selecting Memory Locations

The transmitter ID memory is divided into 10 locations, one per each transmitter ID. Memory locations may be selected in ascending order from 1 to 10, by clicking the MCR-304 tamper switch.

The yellow LED indicates which memory location is selected. The information is conveyed by flashing sequences as demonstrated in the following chart:

No. of Clicks	Mem. Loc.	Flashing Sequence of the Yellow LED
One	1 st	☀ — ☀ — ☀
Two	2 nd	☀☀ — ☀☀ — ☀☀
Three	3 rd	☀☀☀ — ☀☀☀ — ☀☀☀
Four	4 th	☀☀☀☀ — ☀☀☀☀ — ☀☀☀☀
Five	5 th	☀☀☀☀☀ — ☀☀☀☀☀ — ☀☀☀☀☀

..... and so on, until the tenth click

☀ = Flash; — = Pause

3.4 Learning Transmitter IDs

A single transmission (Alarm or Tamper or Restore) is required to enroll a transmitter's ID in the MCR-304 memory. A specific transmitter's ID may be enrolled in as many locations as desired.

Note: In case of PIR detectors, in which batteries are already installed, cover the detector's lens to prevent accidental transmission during the learning session.

For "teaching" transmitter IDs, proceed as follows:

A. Remove the MCR-304 cover.

B. Set the OPERATE / LEARN jumper to LEARN as shown at the right. The yellow LED will start flashing at a constant rate.



C. Click the MCR-304 tamper switch the correct number of times to select the desired memory location (see Para. 3.3.). Each click advances to the next memory location. The red LED will show the status of the selected location as follows:

Status	Red LED Response
Location is free	LED Flashes
Location already contains an ID	LED Lights steadily

To clear a "busy" location, refer to Para. 3.5.

D. If the memory location is free, initiate a transmission from the transmitter you wish to enroll in the selected location. Two kinds of response may be expected:

Red LED Response	Significance
Lights steadily	Transmitter ID enrolled
Continues to flash	Transmitter ID <u>not</u> enrolled

Note: You can not enroll a transmitter in a busy location.

E. Repeat Steps B through D for all of the remaining transmitters.

G. When done, quit the LEARN mode by setting the OPERATE / LEARN jumper back to OPERATE, as shown at the right.



CAUTION! While handling the jumper, take care not to touch the delete button located close to the jumper.

Notes:

- (1) If the transmitter used is a wireless detector, remove its battery to prevent accidental transmissions at a later stage of the learning session.
- (2) If you leave the jumper in the LEARN position and no further learning activity takes place for 5 minutes, the LEARN mode will be automatically abandoned.

3.5 Clearing Transmitter IDs

A. Set the OPERATE/LEARN jumper to LEARN. The yellow LED will start flashing at a constant rate.

B. Click the MCR-304 tamper switch the correct number of times (up to 10) to select the desired memory location (see Para. 3.3). The red LED will show the status of the selected location as follows:

Status	Red LED Response
Memory location is free	LED Flashes
Memory location already contains an ID	LED lights steadily

C. Click the DELETE pushbutton on the MCR-304 circuit board once. The red LED will respond as follows:

Red LED Response	Significance
Flashes at a constant rate	Success (ID deleted)
Continues to light steadily	Failure

D. When done, quit the LEARN mode by setting the OPERATE/LEARN jumper back to OPERATE.

3.6 What if the ID is Not Enrolled?

If the transmitted ID has not been accepted although the memory location is free (the red LED continues to flash), try transmitting again. If the second attempt is unsuccessful, the transmitter in question may be faulty. Try enrolling another transmitter.

4. INSTALLATION

4.1 Selecting the Mounting Location

A. The location selected for the MCR-304 must constitute a compromise between maximum reception ability and minimum distance from the control panel.

B. Maintain the antenna vertical - tape it to the wall if required.

C. Avoid installing the MCR-304 on or near large metallic objects such as closets, circuit breaker cabinets, air conditioner ducts and fine-mesh window screens.

D. Do not locate the unit near dense electrical wiring.

4.2 Mounting the Base in Place

To install the cabinet, proceed as follows:

- Hold the base against the mounting surface and mark the points for drilling (see mounting holes in Figure 2).
- Drill the mounting holes and insert wall anchors if necessary. Enter the wires into the base through the wiring knockouts. Attach the base to the mounting surface with two long screws.
- Complete the wiring as described in Para. 4.3.

4.3 Wiring (Figures 4 through 7)

- Connect the relay **N.C.** (or **N.O.**) and **C** terminals of the MCR-304 to the selected zone input of the control panel in use.

Note: If the control panel burglar zone input is defined as E.O.L., use appropriate E.O.L. resistors (see Figure 4).

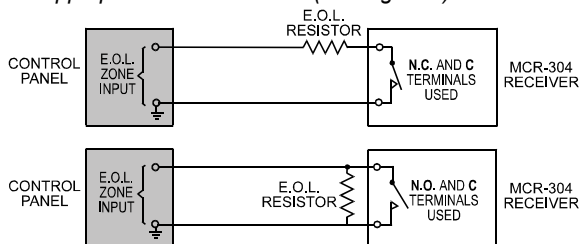

Figure 4. Using E.O.L. Resistors in the Relay Output Circuit

- If you wish to separate between status alerts, connect each status outputs of the MCR-304 (**TAMP**, **LBT** and **TRB**) to a separate zone input of the control panel, as shown in Figure 5.

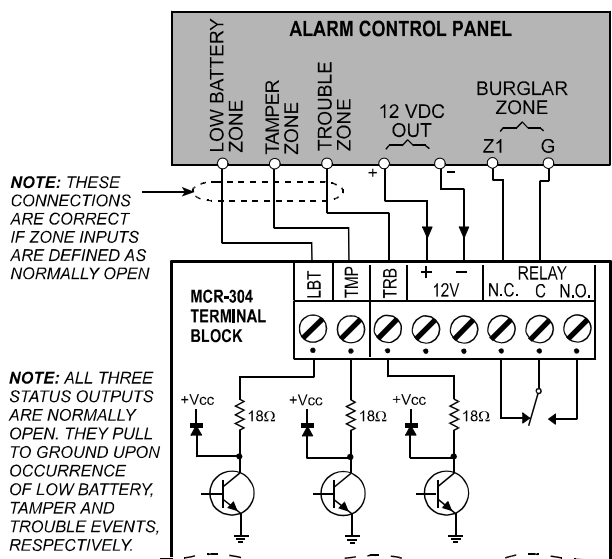

Figure 5. General Wiring Diagram

- If you prefer to use only one zone input for status alerts, connect all 3 status outputs of the MCR-304 to a single zone input of the control panel, as shown in Figures 6 (E.O.L. option) and 7 (relay option).

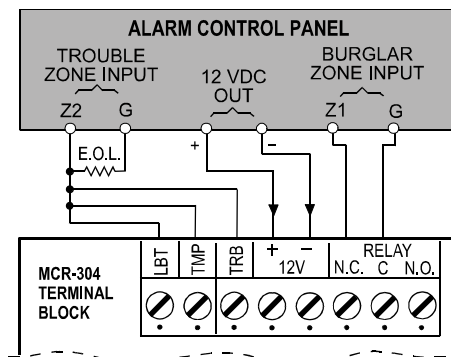

Figure 6. Wiring All 3 Status Outputs to a Single E.O.L. Zone

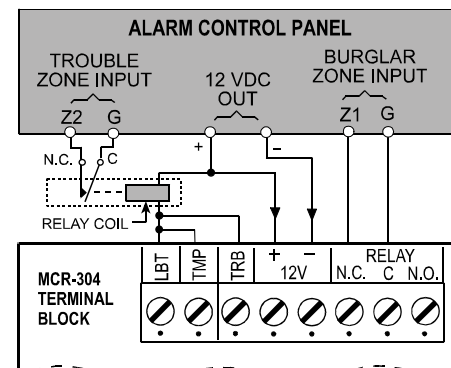

Figure 7. Wiring All 3 Status Outputs to a Single N.C. Zone

4.4 Customizing Your Receiver

After wiring, you must set the relay output operating mode in accordance with the requirements of your specific application.

Note: Instead of alarm management, the relay output of the MCR-304 may be used for Arming/Disarming purposes or for other remote control tasks such as opening / closing a garage door. The PULSE / TOGGLE jumper determines the operating mode of the MCR-304 output relay (Pulse or Toggle):

PULSE MODE

Upon reception of a valid alarm transmission, the output relay pulls in for as long as the transmission is received, plus 3 seconds. The relay will drop out when the "pulse timer" completes its countdown.

Note: If another valid transmission is received during countdown, the pulse timer will be automatically reset and a new countdown will begin.

TOGGLE MODE

The output relay changes state each time it receives a valid alarm transmission. Upon entering a new state, the toggle circuit is inhibited for 3 seconds, to impose a 3-second interval between states.

Note: If another valid transmission is received during the 3-second inhibit period, the inhibit timer will be automatically reset and a new 3-second period will begin.

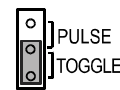
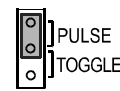

5. MISCELLANEOUS COMMENTS

5.1 The Effect of Transmitter Type on Output Relay Function in the PULSE Mode

The MCR-304 makes a distinction between devices that report alarm only (such as PIR detectors and pendant transmitters) and devices such as magnetic switches or universal transmitters that report both alarm and restore events.

If the MCR-304 is set to PULSE, it will respond to an alarm received from alarm-only devices by energizing its output relay for 3 seconds and then letting it drop out.

However, upon receiving an alarm from one or several restoral-reporting transmitters, the MCR-304 will energize its output relay and will keep it this way until all alarmed transmitters restore.

Note: If the system includes restoral-reporting transmitters, it is not recommended to set the MCR-304 to the toggle mode.

5.2 The Effect of Transmitter Type on the TRB (Trouble) Output

The MCR-304 makes a distinction between supervised and non-supervised transmitters.

Supervised transmitters transmit an "attendance message" at regular intervals. If such a transmitter fails to send this message on time, the MCR-304 will activate its TRB (trouble) output.

On the other hand, failure to receive an attendance message from a transmitter identified as a non-supervised device will be ignored by the MCR-304.

5.3 Product Limitations

Visonic Ltd. wireless systems are very reliable and are tested to high standards. However, due to their low transmitting power and limited range (required by FCC and other regulatory authorities), there are some limitations to be considered:

- A. Receivers may be blocked by radio signals occurring on or near their operating frequencies.
- B. A receiver can only receive one transmitted signal at a time.
- C. Wireless equipment should be tested regularly to determine whether there are sources of interference and to protect against faults.

The user is cautioned that changes or modifications to the unit, not expressly approved by Visonic Ltd., could void the user's FCC authority to operate the equipment.

This device complies with the European Council Directive EMC 89/336/EEC & 92/31/EEC and bears the CE mark and certification.

This device has been tested and found to comply with the limits for a Class B digital device, pursuant to Part 15 of the FCC Rules. These limits are designed to provide reasonable protection against harmful interference in residential installations. This equipment generates, uses and can radiate radio frequency energy and, if not installed and used in accordance with the instructions, may cause harmful interference to radio and television reception. However, there is no guarantee that interference will not occur in a particular installation. If this device does cause such interference, which can be verified by turning the device off and on, the user is encouraged to eliminate the interference by one or more of the following measures:

- Re-orient or re-locate the receiving antenna.
- Increase the distance between the device and the receiver.
- Connect the device to an outlet on a circuit different from the one which supplies power to the receiver.
- Consult the dealer or an experienced radio/TV technician.

Transmitter Deployment Table

Memory Location	Type of Transmitting Device	Location / Task / Name of Holder
1		
2		
3		
4		
5		
6		
7		
8		
9		
10		

WARRANTY

Visonic Ltd. and/or its subsidiaries and its affiliates ("the Manufacturer") warrants its products hereinafter referred to as "the Product" or "Products" to be in conformance with its own plans and specifications and to be free of defects in materials and workmanship under normal use and service for a period of twelve months from the date of shipment by the Manufacturer. The Manufacturer's obligations shall be limited within the warranty period, at its option, to repair or replace the product or any part thereof. The Manufacturer shall not be responsible for dismantling and/or reinstallation charges. To exercise the warranty the product must be returned to the Manufacturer freight prepaid and insured.

This warranty does not apply in the following cases: improper installation, misuse, failure to follow installation and operating instructions, alteration, abuse, accident or tampering, and repair by anyone other than the Manufacturer.

This warranty is exclusive and expressly in lieu of all other warranties, obligations or liabilities, whether written, oral, express or implied, including any warranty of merchantability or fitness for a particular purpose, or otherwise. In no case shall the Manufacturer be liable to anyone for any consequential or incidental damages for breach of this warranty or any other warranties whatsoever, as aforesaid.

This warranty shall not be modified, varied or extended, and the Manufacturer does not authorize any person to act on its behalf in the modification, variation or extension of this warranty. This warranty shall apply to the Product only. All products, accessories or attachments of others used in conjunction with the Product, including batteries, shall be covered solely by their own warranty, if any. The Manufacturer shall not be liable for any damage or loss whatsoever, whether directly, indirectly, incidentally, consequentially or otherwise, caused by the malfunction of the Product due to products, accessories, or attachments of others, including batteries, used in conjunction with the Products.

The Manufacturer does not represent that its Product may not be compromised and/or circumvented, or that the Product will prevent any death, personal and/or bodily injury and/or damage to property resulting from burglary, robbery, fire or otherwise, or that the Product will in all cases provide adequate warning or protection. User understands that a properly installed and maintained alarm may only reduce the risk of events such as burglary, robbery, and fire without warning, but it is not insurance or a guarantee that such will not occur or that there will be no death, personal damage and/or damage to property as a result.

The Manufacturer shall have no liability for any death, personal and/or bodily injury and/or damage to property or other loss whether direct, indirect, incidental, consequential or otherwise, based on a claim that the Product failed to function. However, if the Manufacturer is held liable, whether directly or indirectly, for any loss or damage arising under this limited warranty or otherwise, regardless of cause or origin, the Manufacturer's maximum liability shall not in any case exceed the purchase price of the Product, which shall be fixed as liquidated damages and not as a penalty, and shall be the complete and exclusive remedy against the Manufacturer.

Warning: The user should follow the installation and operation instructions and among other things test the Product and the whole system at least once a week. For various reasons, including, but not limited to, changes in environmental conditions, electric or electronic disruptions and tampering, the Product may not perform as expected. The user is advised to take all necessary precautions for his/her safety and the protection of his/her property.

6/91



VISONIC LTD. (ISRAEL): P.O.B 22020 TEL-AVIV 61220 ISRAEL. PHONE: (972-3) 645-6789, FAX: (972-3) 645-6788
 VISONIC INC. (U.S.A.): 10 NORTHWOOD DRIVE, BLOOMFIELD CT. 06002-1911. PHONE: (860) 243-0833, (800) 223-0020 FAX: (860) 242-8094
 VISONIC LTD. (UK): FRASER ROAD, PRIORY BUSINESS PARK, BEDFORD MK44 3WH. PHONE: (0870) 7300800 FAX: (0870) 7300801
 INTERNET: www.visonic.com

©VISONIC LTD 2004 MCR-304 DE3174- (REV. 2 03/04)



MADE IN ISRAEL